

**S
A
L
E
O
R
L
E
A
S
E**



610 E. Knox Dr.

- **LOCATION:** On First Avenue, just south of Roger Road
- **BUILDING SIZE:** 2,348± sf
- **YEAR BUILT:** 1965
- **TAXES:** \$4,055.00 (2008)
- **ZONING:** 0-3 (City of Tucson)
- **PARCEL NUMBER:** 106-01-1060

• **PROPERTY HIGHLIGHTS:** New paint, carpet and general updating allow for immediate occupancy. There is a current certificate of occupancy. Flexible floor plan can easily be reconverted to 2 separate offices. Cat 5 wiring and dedicated 40 amp circuits for servers and /or other electrical equipment.

Sale Price: \$229,000.00

Lease Price: \$12.00/sf/month

Exclusively Represented by:

Mick Cluck

Tucson Realty & Trust Co.
520.577.7000 or 520.349.3533
mcluck@tucsonrealty.com

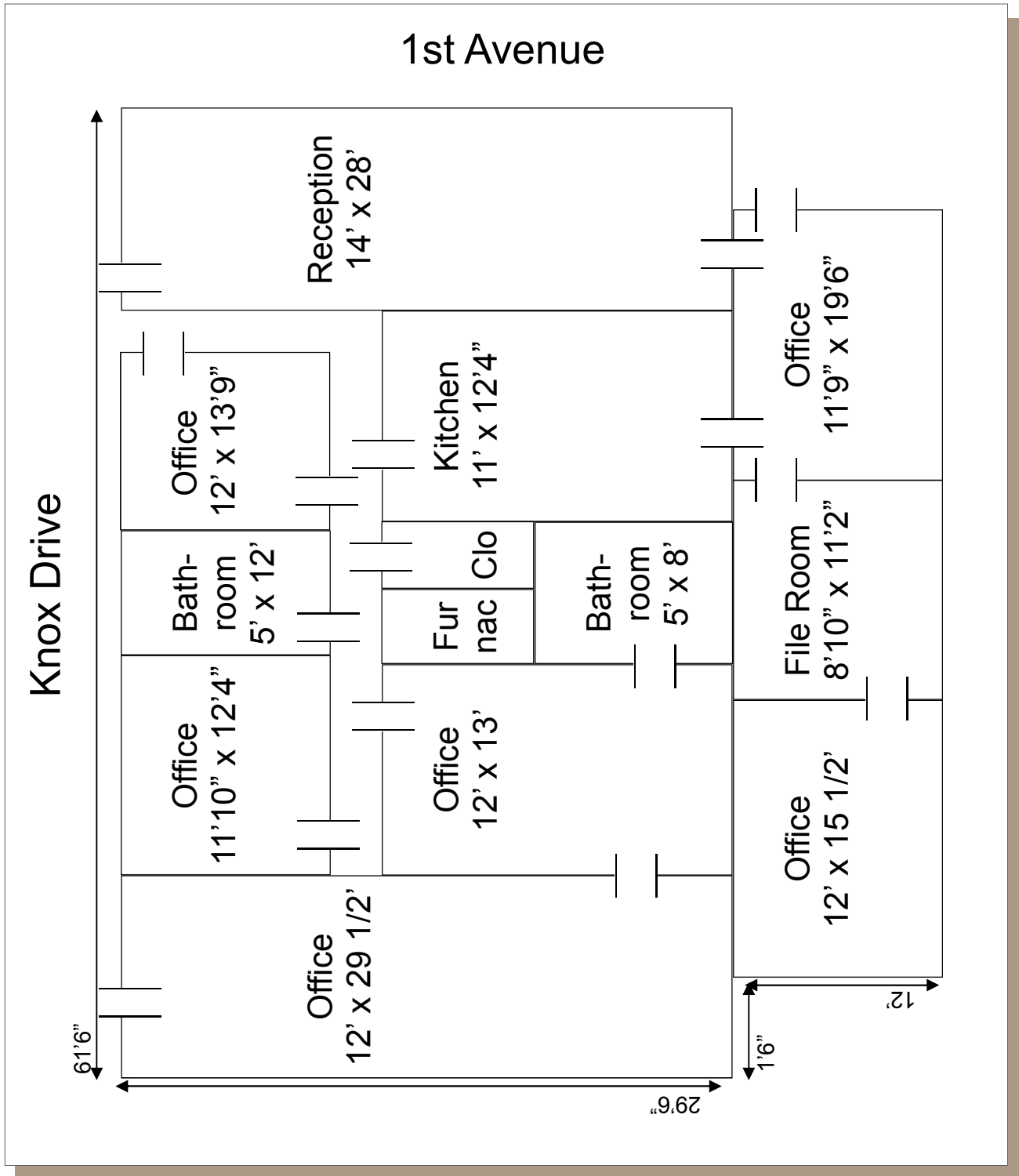

Exclusively Represented by:
Mick Cluck
Tucson Realty & Trust Co.
 520.577.7000 or 520.349.3533
 mcluck@tucsonrealty.com

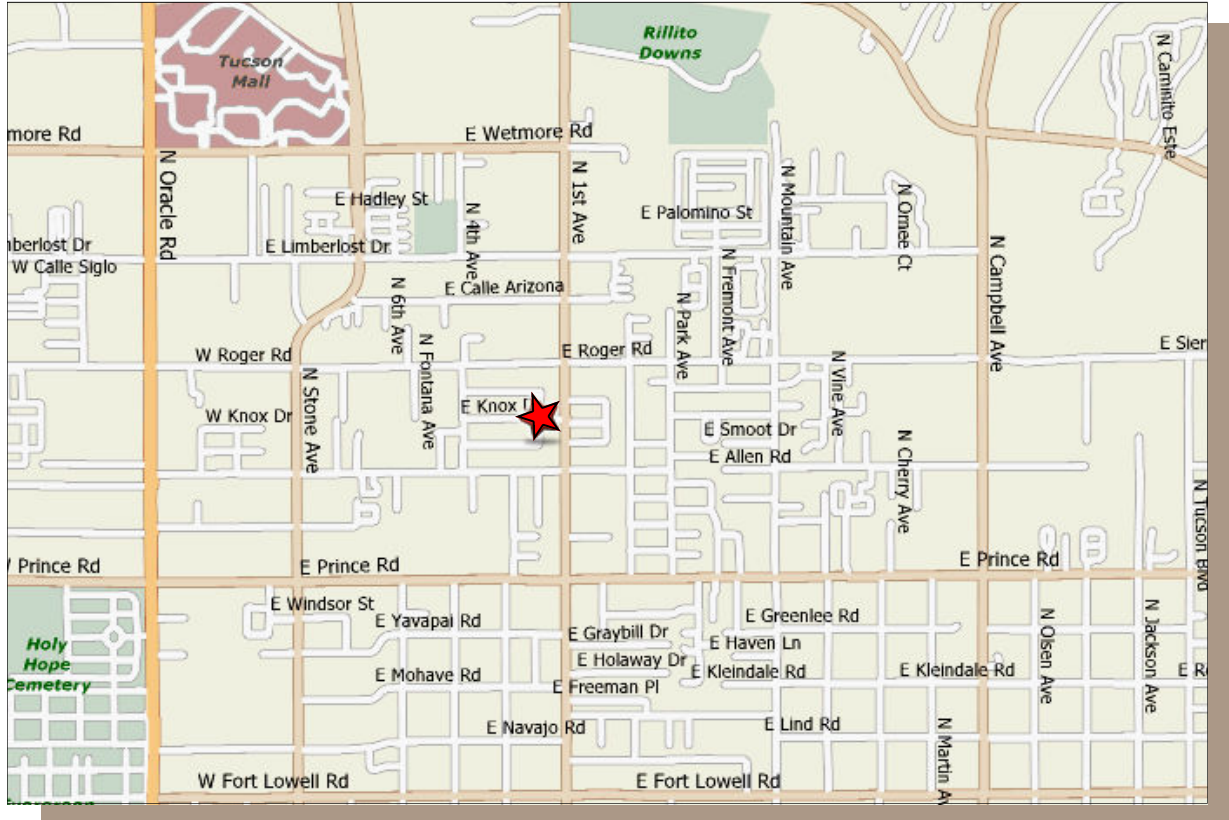

Exclusively Represented by:
Mick Cluck
Tucson Realty & Trust Co.
520.577.7000 or 520.349.3533
mcluck@tucsonrealty.com